

# **Operator Error and Thermal Instability in Industrial Laser Systems**

## ***Three design solutions for the most common problems***

*Brought to you by PolyScience DuraChill® Technology*

### **Executive Summary**

Thermal stability is a critical design objective for industrial lasers. Fabricators and original equipment manufacturers (OEMs) must design their products for careful heat regulation as inadequate temperature control can result in systemic or catastrophic consequences. Fluctuating temperatures impact a laser's capabilities and lifespan, as well as production outcomes and customer satisfaction.

In this technical note, we explore three causes of thermal instability and the solutions that modern recirculating chillers can offer to laser manufacturers. Specifically, we describe the in-field problems that users encounter — and create — when operating a laser system. The prevalence of these problems inspired the creation of the PolyScience DuraChill® line of chillers.

PolyScience's new chiller technologies specifically target maintenance-related issues. The DuraChill® line incorporates innovative features include a self-changing air filter, a front-fill reservoir, and an ultraviolet light fluid sanitation system. Together, these technologies create a more reliable chiller that OEMs can confidently integrate into all their systems.

---

Carbon dioxide (CO<sub>2</sub>) and solid-state lasers require fluid cooling to function. Without adequate cooling from a quality chiller, power stability and lasing precision suffer. Some industrial machines use open-loop cooling, wherein tap water flows through the system and down the drain. This practice is environmentally unacceptable and quickly proves costly — even within a two-year timeframe. More sophisticated designs employ closed-loop cooling. Closed-loop cooling utilizes a heat transfer fluid and a liquid-to-liquid or liquid-to-air heat rejection system. Closed-loop cooling systems offer significant long-term cost savings over open-loop cooling.

### **The Benefits of Improved Temperature Control**

- Better power stability
- Longer laser lifespan
- More consistent beam profiles
- Fewer service calls

A liquid-to-air recirculating chiller is a more adaptable solution that offers precise temperature control. A high-quality recirculating chiller — especially one with advanced usability features — benefits a laser system in several ways, namely by improving the power stability and efficiency, beam profile, mean time between failures (MTBF), and overall lifespan.

### **Power Stability and Temperature**

Power stability is crucial to the reliable operation of a laser system. While there is no standardized mathematical function for defining power stability, the production task at hand quickly illuminates whether a laser is power-stabilized. Unstable power can make the difference between successful cutting at one moment and an insufficient depth at the next. Alternately, over-power fluctuations can leave rough edges that require manual rework. A power monitor placed along the optical path can provide feedback for real-time adjustments to the pump

power. However, robust temperature control should always be the foundational design objective.

To achieve stabilized operation, a laser needs to reach thermal equilibrium by warming to the target operating temperature. Neglecting this important step can cause major power deviations. A quality recirculating chiller warms the laser to the operational temperature quickly, so production can start sooner. Another consideration for the laser is the work environment. The laser system must be operated in the same ambient conditions day-to-day. If the production space changes or is subject to large temperature swings, the laser will struggle with production consistency.

Once the laser has warmed to thermal equilibrium, heat removal takes priority. Only a portion of the laser's electrical input converts to light energy; the rest becomes waste heat in the gain medium or power supply, which causes mechanical thermal expansion. When mechanical components expand, contort, or move, the integrity of the laser is compromised and the beam itself can change, especially when the resonating mirrors move relative to one another. In addition, beam stability drops causing ineffective cutting. When the gain medium increases in temperature, the optical conversion efficiency deteriorates resulting in a reduction of the system's wall-plug efficiency. Overall, operation at high temperatures causes poor performance in an otherwise well-designed laser product.

### *System Maintenance*

Modern recirculating fluid chillers can maintain a transfer fluid temperature within  $\pm 0.1^{\circ}\text{C}$ . ~~But,~~ To do so they must be properly maintained. A production facility's standard operating procedures must include regular chiller air filter changes, condenser cleanings, and recirculating fluid inspections and additions. Occasional troubleshooting is necessary to confirm the chiller's functionality and deduce possible problems within the system.

### **Thermal Instability Cause #1: *Improper Air Management***

A recirculating chiller's ability to remove heat depends on many factors, such as the internal architecture of the application, the thermal conductivity of the transfer fluid, the compressor power, the refrigerants, and the air movement system. Ultimately, those design factors — together with the set point temperature, pressure, and flow rate — determine the chiller's ability to reject heat from the application to the surrounding environment.

In laser systems with recirculating chillers, thermal problems rarely stem from poor equipment or design flaws. More likely, the culprits are operator error and neglected maintenance. Maintenance problems are understandable. In a busy production environment, laser technicians are focused on throughput, not monthly maintenance procedures.

So, it comes as no surprise that PolyScience has documented dirty condensers and obstructed air filters as the cause of 22% of service returns. The returned units are otherwise functional. The prevalence of this problem is troublesome, to say the least. Service returns cost companies thousands of dollars in downtime and hundreds in shipping costs. Moreover, the customer experiencing the problem does not readily distinguish between the chiller manufacturer and the laser OEM. For customers, the problem is simply that their laser — designed and provided to them by the OEM — is creating a headache.

## Top Reasons for Chiller Service Returns

1. Obstructed air filters
2. Dirty condenser fins
3. Fouled or insufficient circulating fluid
4. Cracked evaporators caused by improper fluid use

Obstructed air filters do not always cause power or beam instability. Sometimes the effects are less obvious. Poor air circulation increases electrical costs because the compressor and circulating fan must run harder and longer to achieve the same temperature set point. In addition, running the chiller harder and longer will shorten the chiller's lifespan.

## The World's First Self-Changing Air Filter

The DuraChill® line from PolyScience takes a new approach to the problem of air filter obstruction. Because operators so frequently neglect to change the air filters of their chillers, PolyScience engineers automated the maintenance process. The resulting technology uses a patent-pending roller cartridge system to replace the filter material at user-defined intervals. When the filter needs service, the chiller rolls a fresh filter into place.

The self-changing filter dramatically extends the air-filter maintenance interval. In dirty production environments, users can set a monthly filter-change interval and replace the cartridge annually. In cleaner environments, users save money by extending the interval to several months and replacing the cartridge less frequently. When a new cartridge is needed, the DuraChill® chiller displays a notification, and the operator can replace the cartridge without the need for tools.

## Low-Noise Air Circulation

Operators frequently complain of noisy chillers which result from poorly insulated or low-quality compressors, circulating fans, pumps, and valves. So, PolyScience responded with the WhisperCool® Environmental Control System for the DuraChill® line. The WhisperCool® is a high-efficiency air management technology, built around a fan with an electronically commutated brushless motor. The motor smoothly modulates its power level to as low as 20%, thus meeting the chiller's heat rejection requirement at the lowest possible electrical draw and noise level.

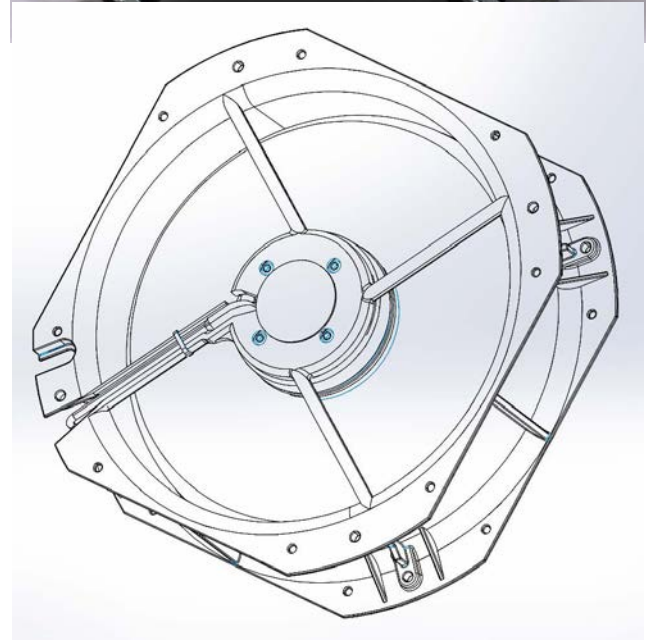

The chiller operates at the noise level of a typical office (62dB).

Further, -DuraChill® features dual stepper motors for valve control rather than traditional pulse width modulation (PWM) valves. The stepper motors precisely and incrementally position the valve. By contrast, PWM valves fully open and close to control the release of the refrigerant, which creates constant clicking and surging noises. The noise is more than an annoyance for the operator; it can prevent them from noticing auditory clues of malfunction elsewhere in the system.

## **Thermal Instability Cause #2: *Neglected Heat Transfer Fluid***

Another critical — yet easily avoidable — source of problems comes from improperly maintaining the heat transfer fluid. When operators fail to maintain the quality or quantity of a chiller's recirculating transfer fluid, the results can be disastrous for the chiller and the laser system, as a whole. In the case of a contaminated fluid supply, internal components can irreparably corrode or become congested with biological contaminants. If the fluid level is too low, the laser system or the chiller could be destroyed. Legacy chiller technologies relied on additive biocides and failure-prone float valves, leaving equipment subject to user error and troublesome moving parts. The DuraChill® line of chillers takes a new approach to both of these common problems.

## **Fluid Sterilization with Ultraviolet Radiation**

Biological contaminants in the recirculating fluid, such as algae, insulate surfaces inside the process and make heat transfer inefficient and imprecise. For decades, chemical additives were used to solve the problem but at a cost to the environment — copper-containing algaecides affected human hormones, waterways, and wildlife. Therefore, to simultaneously protect process equipment and the environment, PolyScience engineers developed an ultraviolet (UV) sterilization system. The system utilizes a high-efficiency light-emitting diode (LED) to significantly reduce biological fluid contamination with wavebands in the UV-C range. To ensure the LED's long-life span, the system employs a sight glass so the LED has no direct contact with the fluid. Every circulation, the fluid is irradiated with UV light which kills biological contaminants without the need for chemical additives.

## **A Front-Fill Reservoir**



When maintenance is difficult or when the equipment being maintained is out of sight, the required service is more likely to be neglected. In response, the DuraChill® line of chillers features a front-fill reservoir for recirculating fluid. This design makes adding fluid easy, even when a chiller is configured under a workstation.

Rather than moving the chiller or rearranging the workspace to add fluid into the back of the chiller, the technician simply removes the front-facing cap. The front-fill feature is

particularly useful when changing the fluid or filling the system for the first time. Upon the first fill, the fluid displaces the air in the supply lines and the level in the reservoir decreases. As the

level drops, the front-fill feature makes adding more fluid easy. This procedure ensures the correct amount of fluid upon initial operation and minimizes the chance of improper fluid levels.

### Capacitive Fluid Level Sensor

When fluid levels drop below the operating threshold, the process and the chiller are both at risk. Within as little as 30 seconds of dry operation, the pump seals can fail. An expensive repair to the chiller is a best-case scenario; damage to the process equipment can be much more costly.

To solve the problem of fluid level maintenance, the DuraChill® line foregoes the float sensors found on older chillers. Float sensors can stick in place and fail to signal a low fluid level. The DuraChill® capacitive sensor, by contrast, has no moving parts and no possibility of age-related failure.



While other chillers use a binary single-alarm alert system, DuraChill® technology features a persistent fluid-level icon that is always visible on the chiller's color display. As the fluid level drops, the icon turns from blue to orange, and then red, which indicates a critically low level. If the fluid level drops below 35% of capacity and there is a risk of air entering the pump, the control system shuts down the chiller and the process and signals another alarm.

### Longevity and Thermal Control

Over its service life, a laser's power output drops by as much as 20%. Most of that loss is due to the degradation of the system's optics. The DuraChill® line of chillers increases the laser system's longevity by ensuring that the laser stays in its thermal specification and is not subject to mechanical thermal expansion which compromises the alignment of the optical components. By reducing over-temperature events, the chiller keeps the RF power supply and other electronics in top condition.

### Thermal Instability Cause #3: Diagnostic Difficulties and User Error

Industrial designers increasingly design for the human element. If high-quality manufacturing systems are tricky to operate, the quality of those systems is negated. Until now, chiller designs have neglected to consider the convenience of the chiller operators, who were left to deal with LCD displays, contextual button interfaces, and error codes that required a manual for interpretation. Sometimes, error codes were immediately serviceable by the operator. Other times, troubleshooting the problem — which was likely caused by neglected maintenance in the first place — required an expensive visit from a skilled refrigeration technician. Often, the visit from the refrigeration tech was simply a litmus test to determine whether a service return was appropriate.

### An Intelligent Self-Diagnostic System

If a chiller is suspected of malfunctioning, there are a limited number of in-field diagnostic procedures that operators can use to assess the problem. Of course, chillers report their operating temperature. But when a chiller struggles to maintain the set point temperature at the

process, the causes — which may include malfunctioning pumps, compressors, valves or air management systems) — may not be easy to recognize.

The DuraChill® line introduces a seven-point self-diagnostic process which automatically compensates for the ambient temperature of the production space. By utilizing a temperature-correction algorithm, the diagnostic system calibrates a direct comparison of the chiller's current functionality to its day-one functionality at the factory. The temperature-corrected comparison provides an accurate assessment of the chiller's health and remaining service life.

#### **The DuraChill® Self-Diagnostic procedure tests:**

- Ambient temperature
- Pump performance
  - Flow measurement at the evaporator
  - Amperage
  - Pressure
- Heating function
- Cooling function
- Temperature stability
- Input voltage

The self-diagnosis system can help operators and technicians deduce fluid fouling, loss of refrigerant charge, ailing pump seals, obstructions to the evaporator's fluid passageways, condenser fouling, failing fans, and the failure of temperature sensors within the laser. Ultimately, the self-diagnosis system helps the operator determine whether a problem should be addressed with a service return, a visit from a refrigeration technician, or if the problem is serviceable by the system operator.

#### **Touchscreen Usability**

To meet the increasing convenience expectations of users, DuraChill® introduces a significant evolution of the chiller interface: a full-color touchscreen. The display simultaneously reports eight critical parameters, allowing the operator to assess the chiller's status in a single glance.

#### **The DuraChill® Color Touchscreen simultaneously displays:**

- Set temperature
- Internal fluid temperature (internal probe)
- Remote fluid temperature (external probe, if fitted)
- Fluid pressure
- Fluid level
- Air filter status
- Active alert status
- UV Light Biological Growth Inhibitor System status

The DuraChill® interface communicates with the operator conversationally, in simple written language (e.g., "Replace the air filter cartridge," "Low fluid level") rather than in alphanumeric codes that require interpretation with a manual. Five language presets are available, making the DuraChill® applicable to most major markets.

## **In Conclusion**

PolyScience can help you configure a user-friendly recirculating chiller for every one of your applications. If you submit the specifications for your system's laser head, we can calculate the ideal pump, fluid, and power capacity for your new chiller. Moreover, we can work within your budget to specify a chiller that will provide your customers with the highest value.

For more information about DuraChill® technologies or selecting the chiller that's right for you, contact a sales representative at [sales@polyscience.com](mailto:sales@polyscience.com)